



PSC-series DC/DC 100 to 150W 1 to 3 Outputs

Input / Output

- Wide input voltage ranges, 10 to 500 Vd.c..
- Single outputs from 5 to 110 Vd.c.
- Two or three outputs 5 to 24 Vd.c. up to 2 A
- Reverse input voltage protection.

Operation

- High efficiency.
- Operating temperature range -25 to +70 °C with no derating.
- Fully encapsulated, meets IP30 as standard.
- Convection cooled.
- Inhibit /Power Down input.
- Low voltage alarm, open collector.

Features

- Conformally coating, tropic.
- Under voltage logic alarm.
- Accesible on front panel:
 - Output voltage adjustment.
 - Output voltage measurement.
 - Output OK status green LED.

EMC

- EN 61000-6-3, Emission.
- EN 61000-6-2, Immunity.
- EN/IEC 61000-4-4, 4 kV.
- EN/IEC 61000-4-5 level 2 & 3.

Input Voltage ranges

Nominal inputs	Input range	Code
12, 24 Vd.c.	10 - 30 V	A
24, 28, 36, 48 Vd.c.	20 - 60 V	B
48, 60, 72 Vd.c.	40 - 100 V	CT
72, 96, 110, 127 Vd.c.	50 - 150 V	C
110, 127, 220, 250 Vd.c.	90 - 270 V	D
350, 440 Vd.c.	250 - 500 V	E

Other input ranges on demand.

T-input for Mobile application ranges

Code	Continous range	Uin 0.1 s -S2
24T	16.8 - 30 Vd.c.	14.4 - 33.6 Vd.c.
36T	25.2 - 45 Vd.c.	21.6 - 50.4 Vd.c.
48T	33.6 - 60 Vd.c.	28.8 - 67.2 Vd.c.
72T	50.4 - 90 Vd.c.	43.2 - 100.8 Vd.c.
110T	77 - 137.5 Vd.c.	66 - 154 Vd.c.

The total output power can be derated on a T-range compared to the above output rating table page 2. Input voltage range according to train standard EN 50155:2001 and IEC 60571:1998.

Single output ratings

Output		
Voltage	Current	Power
5 V	20 - 30 A	100 - 150 W
12 V	8 - 12.5 A	100 - 150 W
15 V	7 - 10 A	100 - 150 W
24 V	4 - 6 A	100 - 150 W
36 V	3 - 4 A	100 - 150 W
48 V	2 - 3 A	100 - 150 W

2 to 3 outputs ratings

Master Output	Auxiliary Output	Total Power
5 V 10 - 20 A	±12 V 1.2 - 2.0 A	100 - 150 W
5 V 10 - 20 A	12 V 1.2 - 2.0 A	100 - 150 W
5 V 10 - 20 A	±15 V 1.2 - 1.7 A	100 - 150 W
5 V 10 - 20 A	15 V 1.2 - 1.7 A	100 - 150 W
12 V 7.3 - 11 A	5 V 2.5 A ²	100 - 150 W
12 V 7 - 11 A	12 V 1.2 - 2.0 A	100 - 150 W
15 V 5 - 8 A	15 V 1.2 - 2.0 A	100 - 150 W
24 V 3 - 4.2 A	24 V 1.2 - 2.0 A	100 - 150 W

2. Common zero on the output.

Single output 100 to 150 W

Features

- Single outputs from 5 to 48 V.
 - Operating temperature range -25 to +70 °C.
 - Fully Encapsulated meets IP30.
 - Convection cooled
 - Low voltage alarm, open collector
 - Inhibit / Power Down input
 - Conformal coating, Tropic
 - Compatible AC inputs models.
- Please ask for PSC-AC Datasheet.



Single Output 100 to 150 W

Output			Input							Case
Voltage	Current	Power	10 - 30 V	20 - 60 V	40 - 100 V	50 - 150 V	90 - 270 V	250 - 500 V		
5 V	20.0 A ¹	100 W	PSC100A5	PSC100B5	PSC100CT5	PSC100C5	PSC100D5	---	10TE	
5 V	30.0 A ¹	150 W	PSC150A5	PSC150B5	PSC150CT5	PSC150C5	PSC150D5	---	10TE	
12 V	8.3 A	100 W	PSC100A12	PSC100B12	PSC150CT12	PSC150C12	PSC150D12	---	10TE	
12 V	12.5 A	150 W	PSC150A12	PSC150B12	PSC150CT12	PSC150C12	PSC150D12	---	10TE	
13.6 V	7.4 A	100 W	PSC100A13.2	PSC100B13.2	PSC100CT13.2	PSC100C13.2	PSC100D13.2	---	10TE	
13.6 V	11.0 A	150 W	PSC150A13.2	PSC150B13.2	PSC150CT13.2	PSC150C13.2	PSC150D13.2	---	10TE	
15 V	6.7 A	100 W	PSC100A15	PSC100B15	PSC100CT15	PSC100C15	PSC100D15	---	10TE	
15 V	10.0 A	150 W	PSC150A15	PSC150B15	PSC150CT15	PSC150C15	PSC150D15	---	10TE	
24 V	4.2 A	100 W	PSC100A24	PSC100B24	PSC100CT24	PSC100C24	PSC100D24	PSC100E24	10TE	
24 V	6.3 A	150 W	PSC150A24	PSC150B24	PSC150CT24	PSC150C24	PSC150D24	PSC150E24	10TE	
48 V	2.1 A	100 W	PSC100A48	PSC100A48	PSC100CT48	PSC100C48	PSC100D48	PSC100E48	10TE	
48 V	3.1 A	150 W	PSC150A48	PSC150B48	PSC150CT48	PSC150C48	PSC150D48	PSC150E48	10TE	

1. Operating temperature range, see 2 outputs
Other input and outputs combination on demand.

How to read our product code:
Example **PSC100C24**
PSC100 = Family code
C = input voltage code
24 = Output voltage 24 V

Pin-out, Single output

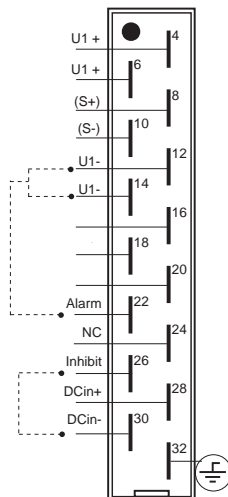

Figure 1. Pin-out single output with connector DIN41612, H15.

Pin-out 2 & 3 outputs

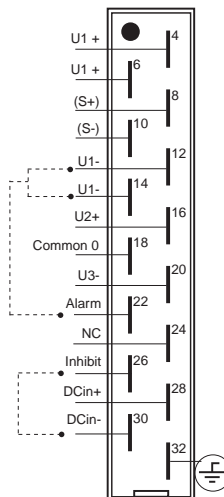

Figure 2. Pin-out 2 to 3 output with connector DIN41612, H15.

High Power 2 & 3 Outputs 100 to 150 W

Features

- Master Outputs from 5 to 48 V
 - One auxiliary voltage 5 to 30V
 - Second auxiliary voltage 5 to 15 V
 - Operating temperature range -25 to +70 °C. +70 °C with derating.
 - Fully Encapsulated meets IP30.
 - Convection cooled
 - Low voltage alarm, open collector
 - Inhibit / Power Down input
 - Conformal coating, Tropic
 - Compatible AC input models.
- Please ask for PSC-AC datasheet.



Two outputs all input codes

Master Output	Auxiliary Output	Total Power	Input					Case
			10 - 30 V	20 - 60 V	40 - 100 V	50 - 150 V	90 - 270 V	
5 V 17 A	12 V 1.2 A	100 W	PSC100A5S12	PSC100B5S12	PSC100CT5S12	PSC100C5S12	PSC100D5S12	10TE
5 V 20 A	12 V 2.0 A	124 W	PSC150A5S12	PSC150B5S12	PSC150CT5S12	PSC150C5S12	PSC150D5S12	12TE
5 V 17 A	15 V 1.2 A	100 W	PSC100A5S15	PSC100B5S15	PSC100CT5S15	PSC100C5S15	PSC100D5S15	10TE
5 V 20 A	15 V 2.0 A	130 W	PSC150A5S15	PSC150B5S15	PSC150CT5S15	PSC150C5S15	PSC150D5S15	12TE
12 V 7.3 A	5 V 2.5 A ²	100 W	PSC100A12S5	PSC100B12S5	PSC100CT12S5	PSC100C12S5	PSC100D12S5	10TE
12 V 11.5 A	5 V 2.5 A ²	150 W	PSC150A12S5	PSC150B12S5	PSC150CT12S5	PSC150C12S5	PSC150D12S5	12TE
12 V 7 A	12 V 1.2 A	100 W	PSC100A12S12	PSC100B12S12	PSC100CT12S12	PSC100C12S12	PSC100D12S12	10TE
12 V 10.5 A	12 V 2.0 A	150 W	PSC150A12S12	PSC150B12S12	PSC150CT12S12	PSC150C12S12	PSC150D12S12	12TE
15 V 5.5 A	15 V 1.2 A	100 W	PSC100A15S15	PSC100B15S15	PSC100CT15S15	PSC100C15S15	PSC100D15S15	10TE
15 V 8 A	15 V 2.0 A	150 W	PSC150A15S15	PSC150B15S15	PSC150CT15S15	PSC150C15S15	PSC150D15S15	12TE
24 V 3 A	24 V 1.2 A	100 W	PSC100A24S24	PSC100B24S24	PSC100CT24S24	PSC100C24S24	PSC100D24S24	10TE
24 V 4.2 A	24 V 2.0 A	150 W	PSC150A24S24	PSC150B24S24	PSC150CT24S24	PSC150C24S24	PSC150D24S24	12TE

Operating temperature range -25 to +55 °C. For 70 °C derate PSC100 to 75 W and PSC150 to 110 W.

2. Common zero on the output.

The secondary output voltage are only factory adjustable.

Higher continuous auxiliary current up to 2.5 A if the input voltage range is derated.

Three outputs 24, 48 Input codes

Master Output	Auxiliary Output	Total Power	Input		Case
			10 - 30 V	20 - 60 V	
5 V 14 A	±12 V 1.2 A	100 W	PSC100A5S12-12	PSC100B5S12-12	10TE
5 V 20 A	±12 V 2.0 A	150 W	PSC150A5S12-12	PSC150B5S12-12	12TE
5 V 13 A	±15 V 1.2 A	100 W	PSC100A5S15-15	PSC100B5S15-15	10TE
5 V 20 A	±15 V 1.7 A	150 W	PSC150A5S15-15	PSC150B5S15-15	12TE

See comments below

How to read our product code:

Example **PSC150B12S5**

PSC150 = Family code & output power

B = Input voltage code

12 = Master output

S5 = Stabilized slave output

Three outputs 110, 220 Input codes

Master Output	Auxiliary Output	Total Power	Input			Case
			40 - 100 V	50 - 150 V	90 - 270 V	
5 V 14 A	±12 V 1.2 A	100 W	PSC100CT5S12-12	PSC100C5S12-12	PSC100D5S12-12	10TE
5 V 20 A	±12 V 2.0 A	150 W	PSC150CT5S12-12	PSC150C5S12-12	PSC150D5S12-12	12TE
5 V 13 A	±15 V 1.2 A	100 W	PSC100CT5S15-15	PSC100C5S15-15	PSC100D5S15-15	10TE
5 V 20 A	±15 V 1.7 A	150 W	PSC150CT5S15-15	PSC150C5S15-15	PSC150D5S15-15	12TE

Operating temperature range -25 to +55 °C. For 70 °C derate PSC100 to 75 W and PSC150 to 110 W.

The two secondary outputs use common zero for ±12 or ±15 application or to supply -24 V or 30 V.

The secondary outputs voltage are only factory adjustable.

Higher continuous auxiliary current up to 2.5 A if the input voltage range is derated.

Auxiliary outputs

Master - slave

The PSC-series uses a master slave configuration on the auxiliary outputs. The main power circuit is regulated by the master output. The auxiliary circuits use step down regulators. The advantage is high efficiency in all parts and we can supply continuously 1.2 A on each of the auxiliary voltages. On special demand we can supply units with higher continuous auxiliary voltage. The disadvantage is that the master output need to take minimum 1/3 of the total load and do not supply any current if the master is unloaded.

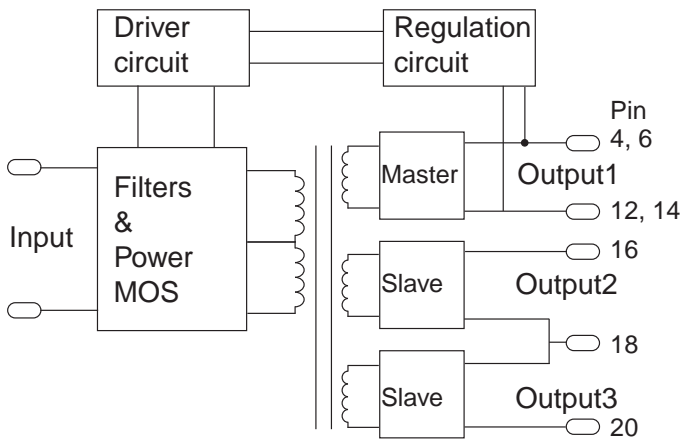

Figure 3. Master slave configuration.

Auxiliary voltage current characteristic

Each auxiliary output is regulated by a step down regulator that have a continuous output current of 1.2 to 2.0 A. A peak current during 2 to 3 ms can be supplied up to 3 A.

The current is protected by the faster current limit and a slower thermal limit.

The voltage regulation is 2 % (0 to 100 % load).

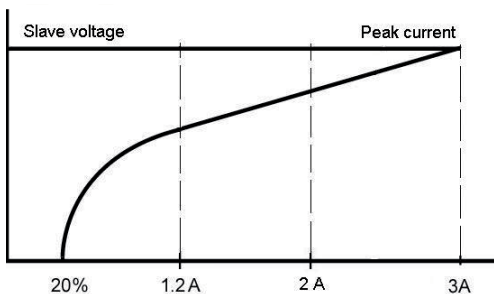

Figure 4. Current characteristic on slave voltage.

If the input voltage range is limited to handle a specific battery voltage the auxilliary continuous current can be increased to 2.5 A, please contact factory or your local contact.

Features

Under voltage logic alarm

On DC-inputs a built in logic alarm changes to alarm state if the converter output voltage drops 10 % below nominal output. The DC OK LED is also controlled by the alarm circuit.

The alarm has an open collector configuration.

A voltage < 1 V is normal operating condition.

In alarm state the output can drive max 20 mA 60 V.

The logic alarm works if a voltage is applied through a resistor on the collector output max voltage 60 V.

For relay output, see option B.

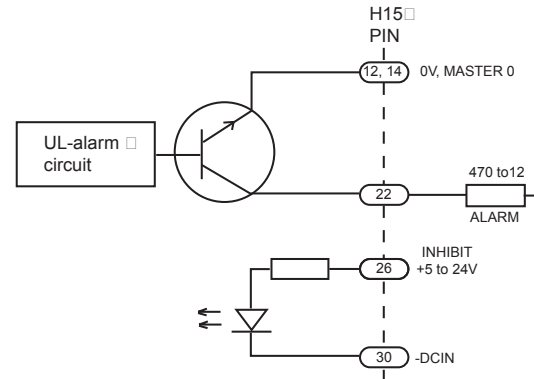

Figure 5. Open collector alarm and inhibit input.

Inhibit – power down signal

To stop the converter, an external voltage (5 to 24 V) can be put between pin 26 and input zero (pin 30), see page 3.

Do not use the output voltage to supply the inhibit.

Reverse input voltage protection

Is provided by a parallel diode on the input.

This diode is only intended to blow an external input fuse. See option K for more possibilities.

Inrush current limit

A NTC resistor is provided on models with input code 220.

Adjustment & measurement

Output voltage adjustment potentiometer and output voltage measurement points are accessible from the front panel.

Conformal coating

The PSC-series is conformally coated to withstand non-condensing tropical environment Rh 95 %.

Optional Features

Overvoltage protection OVP-A

The output voltage is limited to 15 % over nominal output voltage. A SCR short-circuits the output. It is reset by switching off the input or by an Inhibit signal. The OVP circuit is a standard feature on 5 V outputs, which triggers at 6.2 V.

Undervoltage alarm with relay -B

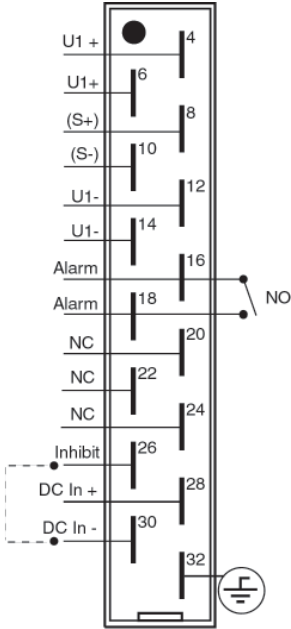

The standard under voltage logic alarm circuit output is replaced by a relay fault signalling output. The relay logic is NO (Normally Open) in alarm state. (Alarm state = no input or low output.) The relay rating is 30 V 0.5 A (a.c. & d.c.) Connect according to figure between Pin 16 and 18 on the H15 connector. Only possible on single output.

On PSC100 & PSC150 with E input code models the user can select NO or NC function. Then pin20 is also used.

Built in series diode -C

A series diode on the output, which is mounted inside the case. Use this option when output is connected in parallel with other power supplies to achieve redundancy.

Remote sense -S

The voltage sensing can be put at the load to compensate for voltage drop. Is a standard feature on 5 V output.

Inrush current limit with NTC

Reduce the inrush current during start up. The input voltage range might be affected. This feature or option is not recommended for stand-by operation (One supplies the load and the other is used as an idling back-up). The stand-by unit might not be able to supply enough current until the NTC warms up.

Input diode for reverse voltage protection - K

Parallel diode reverse protection is a standard feature.

K1. Reverse protection with a series diode on the input. The input voltage range is affected with 1 V higher start/stop voltage. On A and B this option derates the output power by the increased heat losses produced by such diode. Contact factory for details.

K2. Addition of a glass fuse. Can not be used on higher inputs than 180 Vd.c.

2.5 kVa.c. isolation Input/case -E1

On 24 and 48 inputs. The emission level increase to level A.

2.5 kVa.c. isolation Output/case -E2

The emission level increase to level A.

Euro panel -L, 10TE, 12TE see figure 8

Wall mounting panels -N, see figure 9 & 10

Includes H15 connector holder. The female connector has to be added. To mount on a DIN TS-35 rail, we can supply an optional DIN rail clips.

Connector Options



H15 female Screw Connector H15-S



FastOn 6.3mm Connector H15-T



DIN-rail Clips

General data DC/DC Converters

Design topology	Push-Pull
Switching frequency	50 kHz
Emission / Immunity	See below
Safety EN/IEC 60950	Class I
Max accepted input ripple 50 - 400 Hz	1 % of nom. voltage
Power consumption at no load	3 to 5 W
Reverse input voltage protection	Parallel diode
Inrush current limit with Input code A, B, CT Input code C Input code D, E	No Optional NTC Yes with NTC
Insulation	See below

Safety and EMC



PSC-Series meets the requirements defined by CE mark as apparatus.

PSC-Series meets requirements of EMC directive and low voltage directive (LVD).

Thus a PSC-series can be used as free standing unit or in installations as well as systems designed according to "The modular approach".

PSC-series can be used in installation without further EMC tests, if our installation instructions are followed. Please note that product standards can demand different levels or other basic standard tests. We test according to levels below. For higher levels or other tests, contact factory.

Safety standard IEC 60950

Isolation testable levels input code		
	A, B, CT	C, D, E
Input / Output:	2 kVd.c.	2.5 kVa.c. / 4 kVd.c.
Input / Case	2 kVd.c.	2.5 kVa.c. / 4 kVd.c.
Output / Case all outputs	2 kVd.c.	2 kVd.c.
Master output / Auxiliary outputs	2 kVd.c.	2 kVd.c.
Alarm / Input	2 kVd.c.	2.5 kVa.c. / 4 kVd.c.
Isolation, not testable level Safety isolation		
Transformer isolation In / Out:	2 kVd.c.	4 kVa.c. / 8 mm

Output data

Source regulation	0.2 %
Load regulation (0 to 100 % load) master	0.2 %
Cross regulation 25 to 100 % load step on master	0.2 %
Secondary regulation 0 to 100 %	2 %
Transient recovery time for load step of 10 to 100% voltage deviation	<2 ms 3 %
Output ripple (50 kHz) Vp-p ² Input ripple attenuation on output 50 to 400 Hz	Typ. 10 mV 150:1
Emission / Immunity	See below
Temperature coefficient	0.02 %/°C
Min output adjustment range adjustable with a 15 turn potentiometer	90 to 110 %
Current limit, rectangular	105 %
Remote sense	Option S
Soft start	Yes
Isolation output / case	See below
Start-up time	1 s
Hold-up time, contact factory	2-25 ms
Efficiency ³	80 - 91 %
Operating temperature range at 100 % load. Conduction cooling Single outputs >10 V Single outputs <10 V Dual % tripple outputs	-25 to +70 °C -25 to +55 °C -25 to +55 °C
Storage temperature range	-40 to +85 °C

- Output ripple might increases when EN/IEC 61000-4-3 10 V/m test is applied to max 0.5 % V_{RMS}
- Lowest efficiency measured within the whole input voltage range at 100 % load.

We use the product standard Low voltage power supplies, DC outputs EN/IEC 61204-3 and the generic EMC stadards: EN/IEC 61000-6-2 (Immunity) EN/IEC 61000-6-3 (Emission)

EMC

EMC-standards	EMC-performance		
Emission standards	Input	Output	Remarks
EN 55011/EN 55022 (0.15-30 MHz)	Level B	Level B	
EN 55011/EN 55022 (30-1000 MHz)	Level B		Enclosure test
Immunity standards	EN/IEC 61000-6-2		
EN/IEC 61000-4-2	8 kV / 15 kV		Contact / air, Enclosure test
EN/IEC 61000-4-3	10 V/m AM-Modulated		Output ripple can increase to 0.5 % of Vout Enclosure test
EN/IEC 61000-4-4	4 kV	4 kV	
EN/IEC 61000-4-5, Input code 24, 48 EN/IEC 61000-4-5, Input code 1101, 220 ¹ , 440 ¹	0.5 kV / 1 kV 1 kV / 2 kV	0.5 kV / 1 kV 0.5 kV / 1 kV	Line-line 2 Ω / Line-case 12 Ω
EN 50121-3-2/IEC 62236-3-2	1 kV / 2 kV	1 kV / 2 kV	Line-line 42 Ω / Line-case 42 Ω
EN/IEC 61000-4-6	10 V _{RMS}	10 V _{RMS}	AM-Modulated
EN/IEC 61000-4-8	Not sensitive		Enclosure test
EN/IEC 61000-4-10	Not sensitive		Enclosure test

¹ Higher level 2 kV / 4 kV with external filters, contact factory.

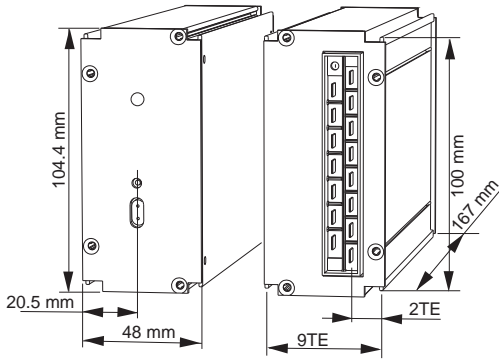

Figure 6. Front and connector side of PSC100

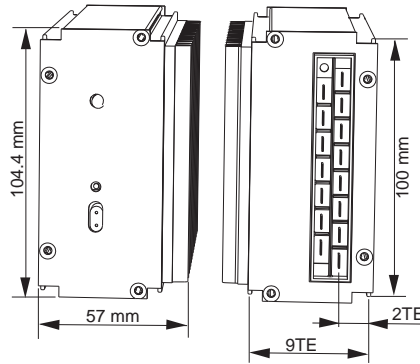

Figure 7. Front and connector side of PSC150

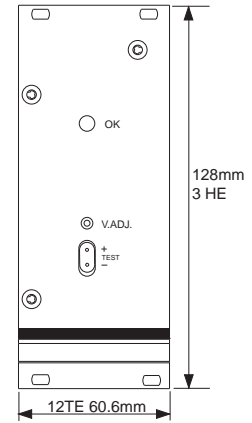

Figure 8. Front panel 3HE option L

The PSC-family are built in a tubular aluminium extrusion, with high thermal conductance which also work as a good EMC shield. The mechanical design permits use in vehicles and heavy industrial environments. The IP class is IP30. On special demand up to IP54 can be supplied using special connectors.

Vibration and shock resistance is high in standard DIN 431605: 6 g 10 ms (5000 times in 3 directions) Higher as 15 g 50 ms or 30 g 10 ms can also be provided on demand.

Type	PSC100	PSC150
d (mm)	50.4	60.6
d (TE)	10	12
Weight: 1 output	1.0 kg	1.2 kg
Weight: 2 & 3 outputs	1.1 kg	1.3 kg
Wall mounting set		
e (mm)	53	63
Weight incl. connector	1.2 kg	1.3 kg

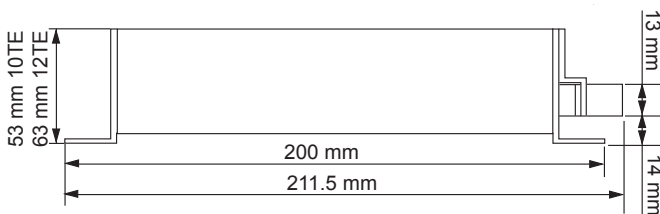

Figure 9. Side view on wall mounting option N

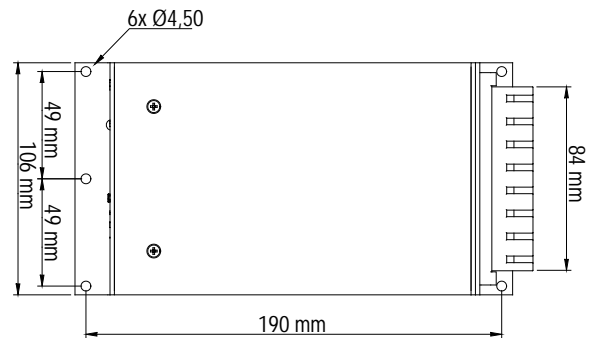
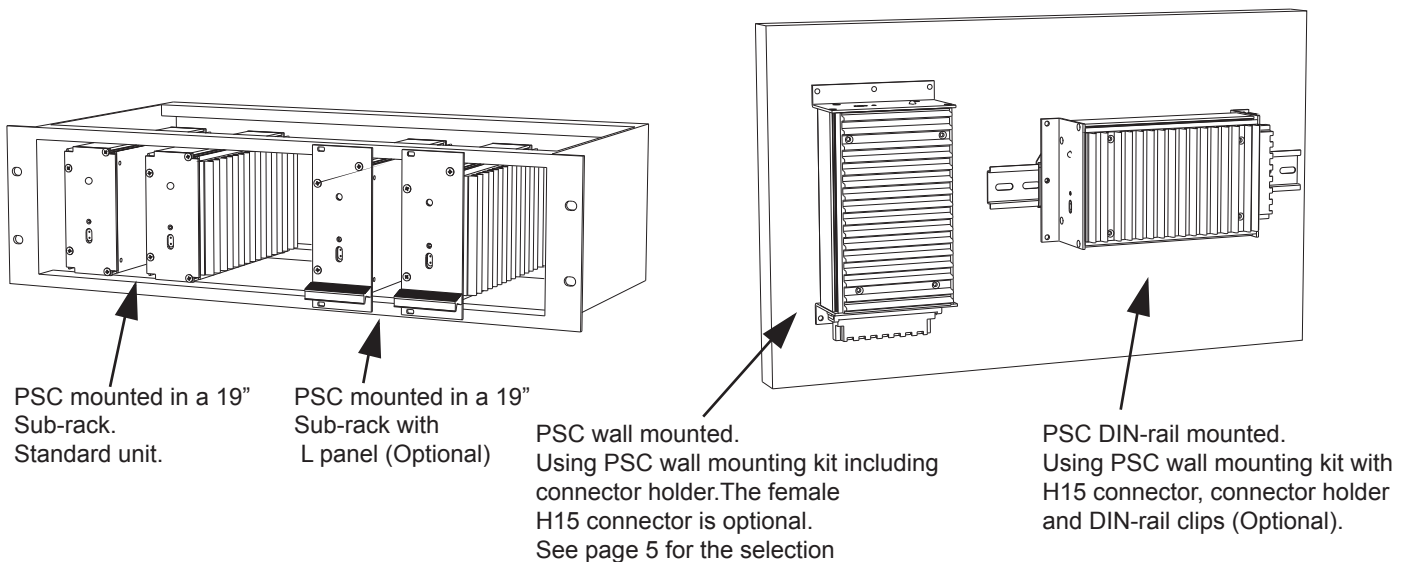

Figure 10. Top view on wall mounting option N



Note: Wall mounting is standard on the swedish market.



PSC mounted flat panel on external cooler



PSC Series with 19"-sub rack
Euro front panels option L.



The Switch Craft Plant, 1100 m above sea level

Switch Craft Plant

Switch Craft S.A. is located in La Chaux-de-Fonds in the Jura mountains in Switzerland. The main products are the Eurocassette families of PSC and PSE converters. Polyamp supports the sales and marketing activities but Switch Craft handle all support to the distributors.

Contact

For updates on this datasheet we refer to www.polyamp.com
Specifications subject to change without notice.



Switch Craft S.A. Ruel bel Air 63
CH-2300 La Chaux-de-Fonds Switzerland
Telephone: +41 32 96 78800 Telefax: +41 32 96 78809
E-mail: terranova@switchcraft.ch

Polyamp AB Box 229 597 25 Åtvidaberg Sweden
Telephone: +46 120 85 400 Telefax: +46 120 85 405
<http://www.polyamp.com>
E-mail: info@polyamp.se

Distributor